

DON'T SEARCH. FIND!

The DVM6 digital microscope

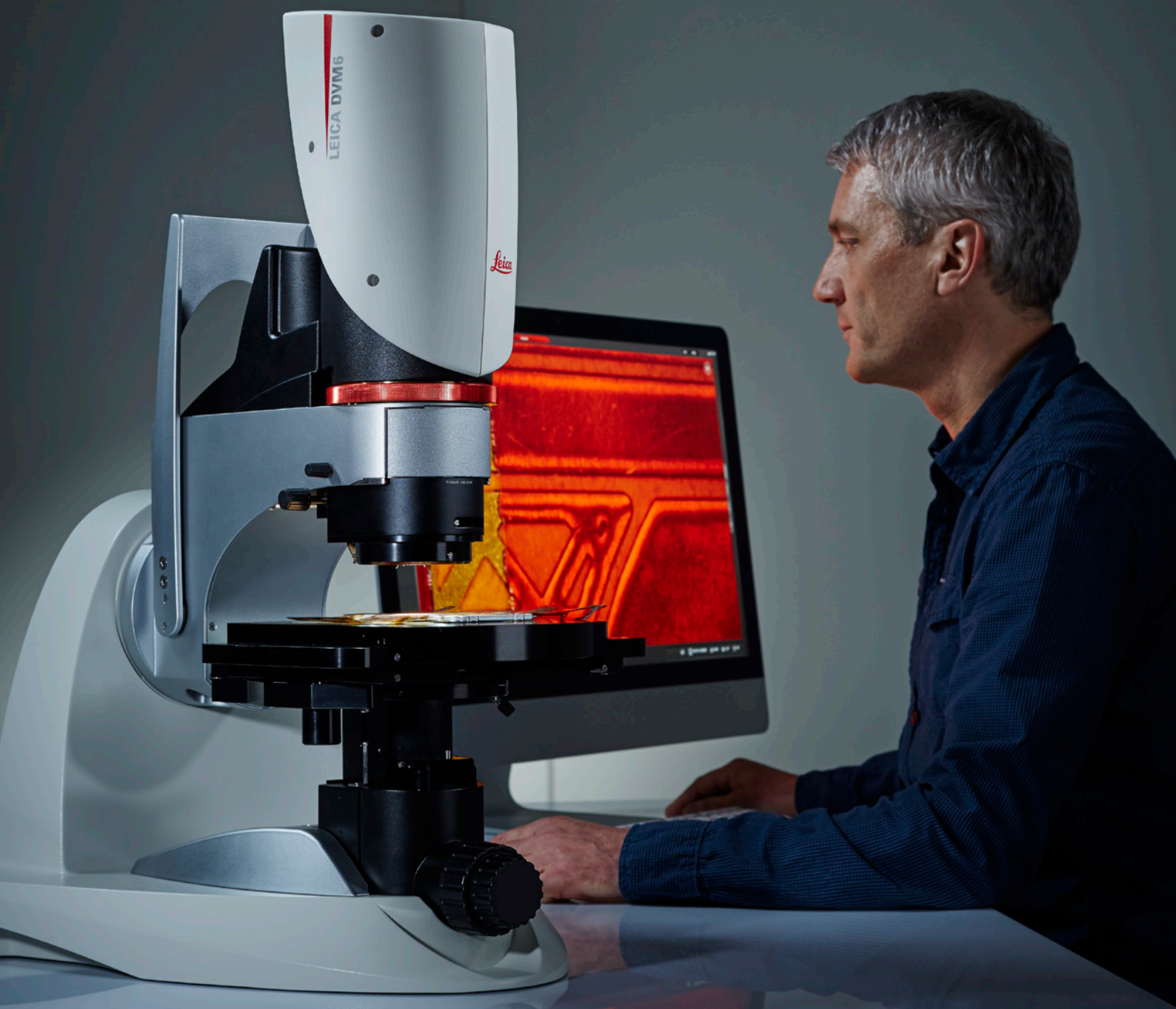

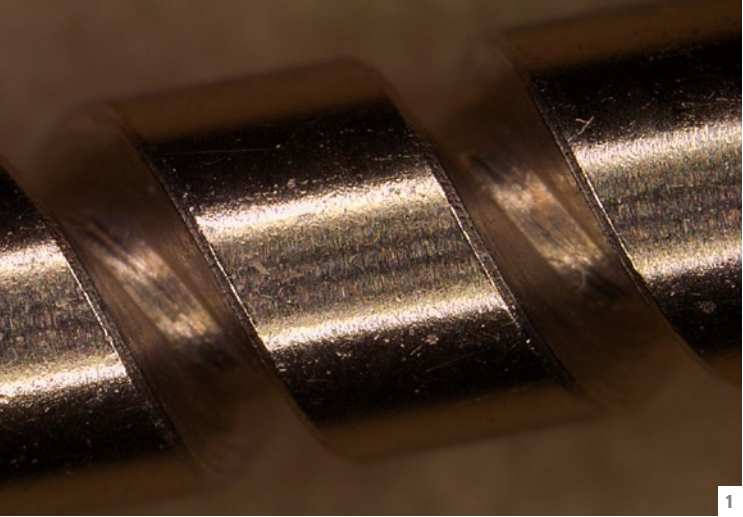

1 2

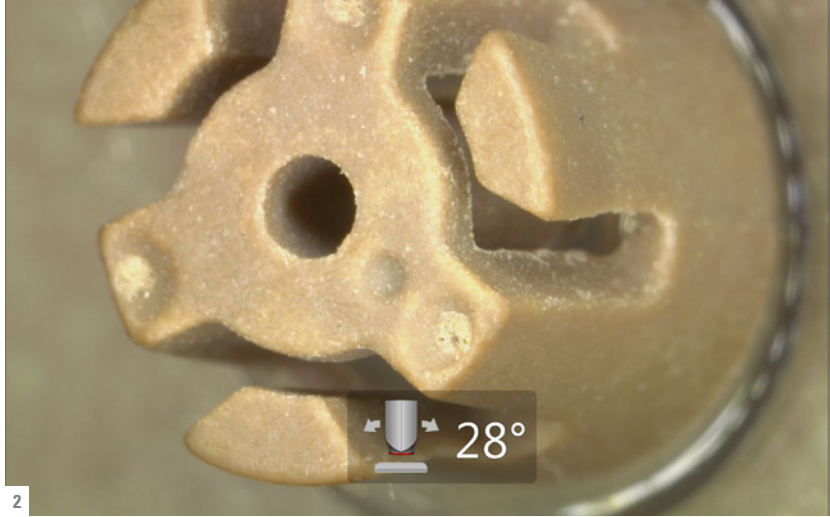

**Don't search. Find!**

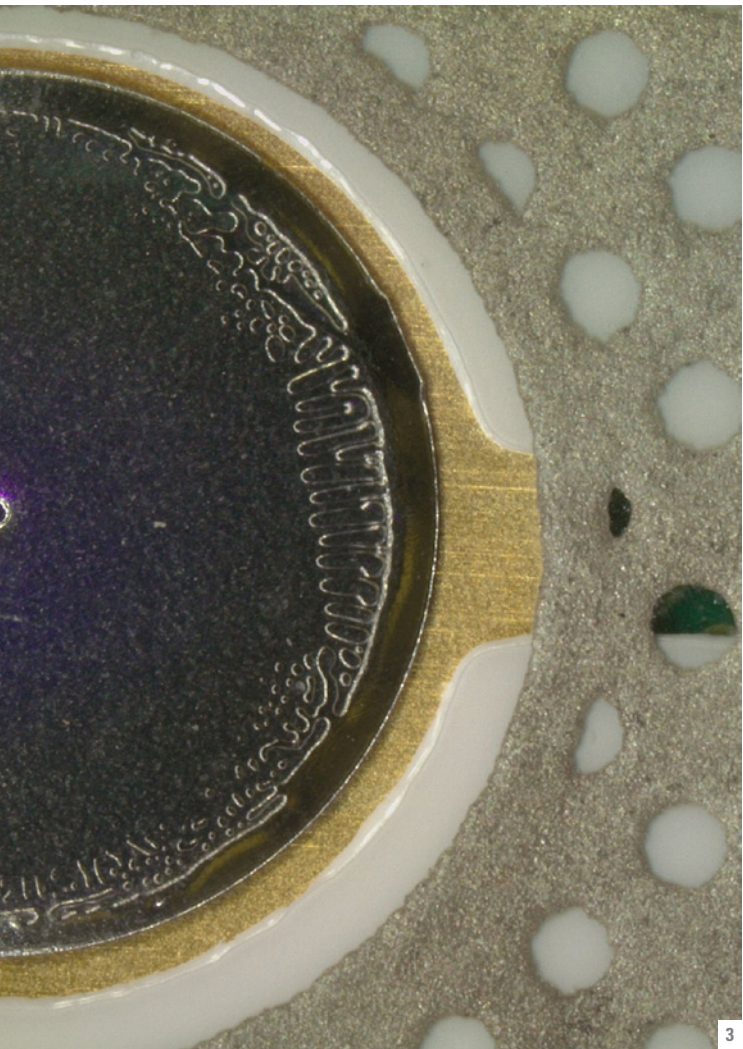

3 4

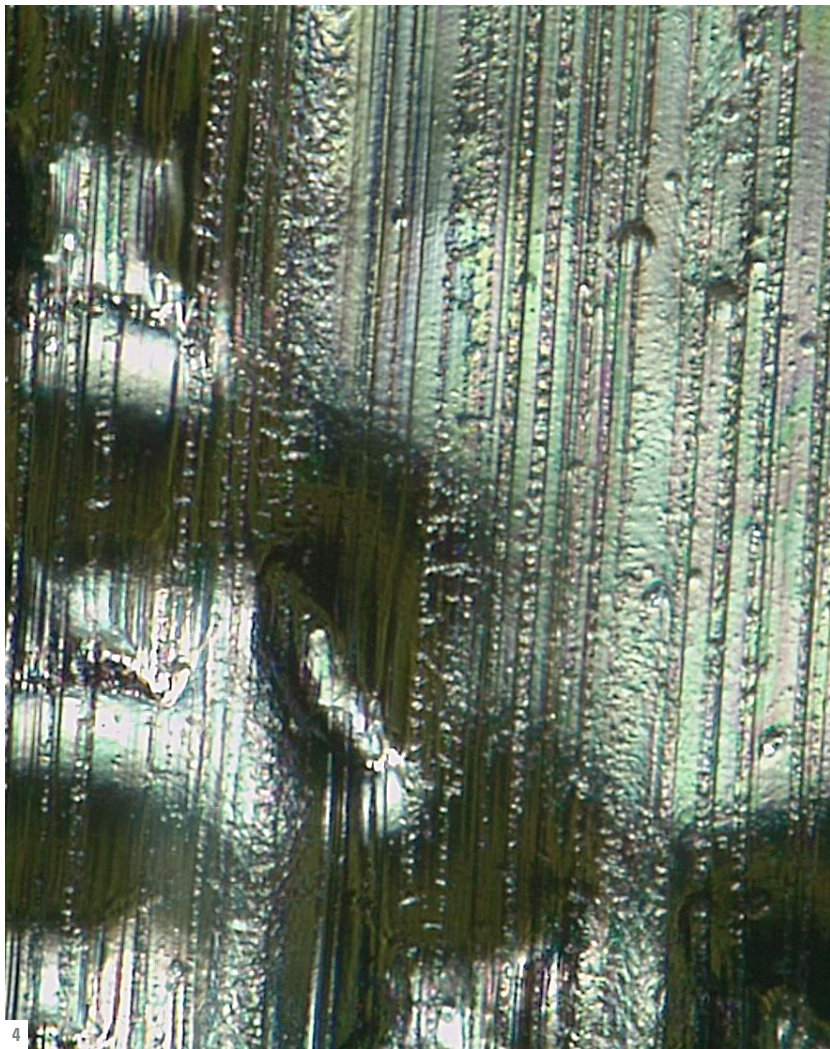

# PUT AN END TO LONG SEARCHES

The DVM6 digital microscope solution is fast, reliable, and easy to use – no matter if you work in quality assurance, failure analysis, research and development, or forensics.



## USABILITY

### One step from macro to micro:

- Change magnification fast, thanks to a wide 16:1 zoom range
- Work from 12x up to 4,740x magnification\* and change the objective with one hand
- Stay focused, always, with easy one-handed tilting

\* based on 1:1 display (10 megapixel)

## IMAGE QUALITY

### See more with crisper images:

- Discover more details with the high-resolution 10 megapixel camera
- See images in high resolution with top-notch optics
- Get your image with one click via the Image Preview function

## IMPRESSIVE INSIGHTS

### Rely on reproducible results:

- Few clicks to generate a report of results
- System settings are always saved with every image, e.g., position, magnification, illumination

1: Spindle - 63x with HDR, ringlight and coax  
2: Injection moulding - 70x, tilted

3: Membrane switch - 60x  
4: Embossed Al-paper - 730x, food packaging



## EASE OF USE

From the big picture to fine details in an instant. Even an objective change does not interrupt your workflow. The DVM6 works straightforward and saves you time inspecting various samples. This solution enables users to start working with minimal training requirements.

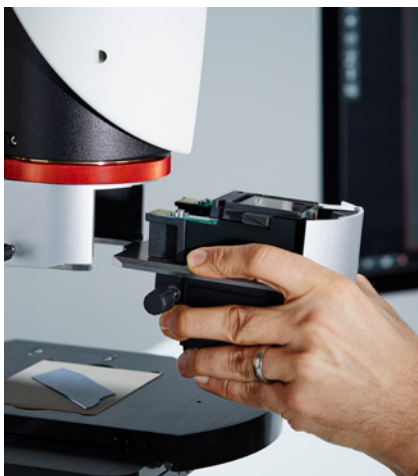

### OBJECTIVE CHANGE: PLUG AND SEE

---

Simply slide in the objective to change to a different magnification. It is a simple one-handed movement while in operation. No additional adjustments, e.g., software setting, cabling, need to be made – parfocal objectives keep the sample in focus.

#### PLANAPO OBJECTIVES:

- PlanAPO FOV 43.75: The objective for large overview (with 45 mm FOV diagonale)
- PlanAPO FOV 12.55: The workhorse with big magnification range (40x-675x) at high working distance (33 mm)
- PlanAPO FOV 3.60: The objective for high resolution (up to 2,350x at 425 nm resolution)



### TILTING STAND: CHANGE YOUR PERSPECTIVE

---

You can tilt the observation angle with one hand. Just concentrate on the monitor to study the sample. By default, the tilting axis is aligned to the focus point so you can see your sample, always in focus, at any angle from  $-60^{\circ}$  to  $+60^{\circ}$ . Rotate the stage and explore the sample from completely new perspectives. This helps you to find the details that you are looking for.

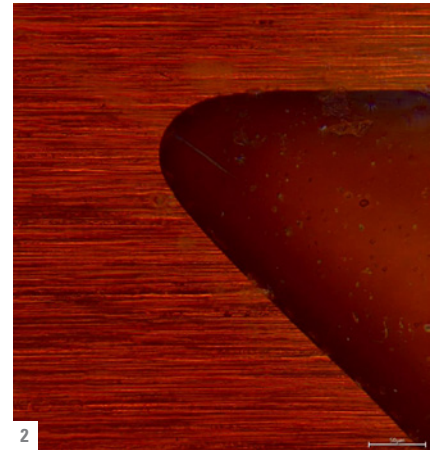

### 16:1 ZOOM RANGE: EXTREME MAGNIFICATION VERSATILITY

Using only one rotational movement, you can zoom in by a factor of 16. The actual magnification of the PlanAPO-corrected zoom optics is displayed on the monitor. This gives you a reference of the imaging conditions.

#### BENEFITS OF PLANAPO OPTICS:

- High optical correction power
- Highly detailed images sharp up to the border area
- No color fringes over zoom range

### AUTOFOCUS: READY – STEADY – SHARP\*

Choose between autofocus and continuous autofocus for your individual tasks. The autofocus of the DVM6 can be applied to any image region (ROI). Stay focused with the DVM6 continuous autofocus.

\* only for DVM6 A



### STAGE POSITIONING AND NAVIGATION

Get the best of both worlds: manual stage movement combined with precise motorized positioning. Reach any point with a 70 mm x 50 mm travel range.



1: Automotive component 1:1  
2: Automotive component 16:1

# BRILLIANT IMAGE QUALITY

To obtain really crisp images you need outstanding optics, a variety of illumination options and a high-performance camera that will capture images in natural colors. The DVM6 offers all that!



## TOP-NOTCH IN OPTICS

---

A digital image can only be as good as the system's optics. Leica Microsystems is a pioneer in the optics industry and among the world leaders in precision micro-imaging. The company history and the passion for delivering sample images in the highest degree of detail and clarity go back more than 160 years. Leica engineers have eliminated optical aberrations and constantly pushed for better resolution – this can be seen immediately with the DVM6.



## 10 MEGAPIXEL CAMERA FOR FAITHFUL RESULTS

---

Unlike digital microscopes that utilize interpolation and time-consuming pixel-shifting, the heart of the DVM6 contains a native 10 megapixel camera. Fast live image display at 30 frames per second allows you natural hand/eye coordination ensuring comfortable operation. Integrating the camera into the zoom module provides the adequate protection against contamination.

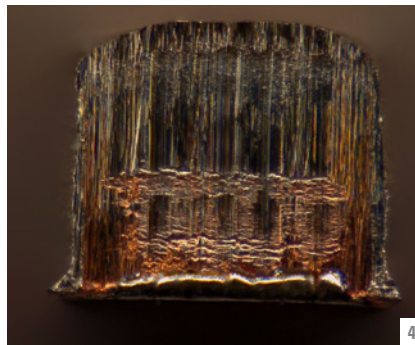
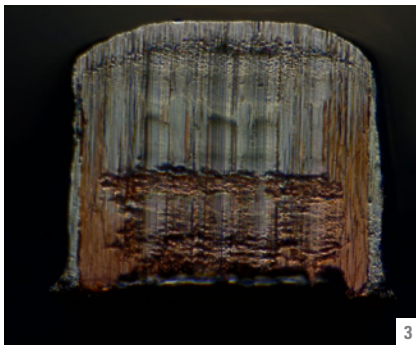

### ILLUMINATION: REVEAL HIDDEN DETAILS

Your choice of illumination determines what you see. Depending on the sample, application, and task, you can choose from different integrated LED illumination options. Use the ringlight – either fully or partially – on textured surfaces, or select the coaxial illumination for flat, reflective samples. You can also combine illumination modes and reveal more details.

#### COAXIAL LIGHT PROVIDES:

- Quarter wave plate control for light/dark control when viewing flat, reflective samples
- Relief contrast for accentuating slight unevenness, such as scratch marks

- 1: Ringlight all four segments
- 2: Adjustment relief contrast
- 3: Metal cut (Sn-plated copper) - 650x, relief contrast
- 4: Metal cut (Sn-plated copper) - 650x, ringlight segment
- 5: Adjustment quarter wave plate

# OPTIMIZED WORKFLOW

Reproduce an image in its entirety with all selected parameters. The digital microscope not only produces crisp images quickly, all systems settings are saved with the picture and can be recalled. This helps you to speed up many processes throughout your work day, especially when it comes to repetitive tasks. And if your microscope is shared among several operators, the encoded functions ensure that every user achieves the same data quality.

## DVM6 DIGITAL MICROSCOPE WITH LAS X.NEXT, THE STREAMLINED SOFTWARE USER INTERFACE

The DVM6 microscope with LAS X.next, the streamlined software user interface, helps you to acquire 2D and 3D scanned images for detailed component analysis in R&D, QC, and failure analysis (FA). LAS X.next makes work steps clear, simple, and intuitive for operators due to its streamlined user interface and image navigator.

It guides you through image acquisition, measurement\*, and reporting, providing reliable reproducibility of results.

# 2D AND 3D ANALYSIS

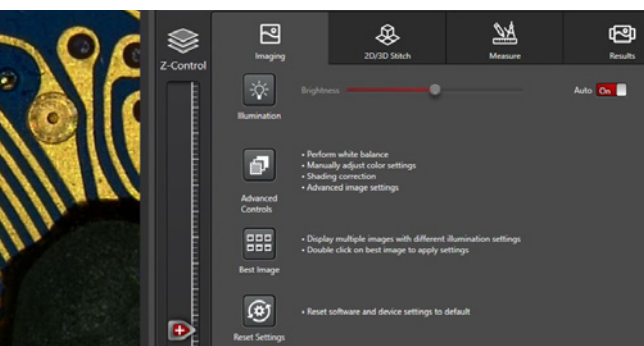

## IMAGING

Supportive algorithms allow you to quickly find the right illumination setting using a slider control. You can also choose from different illumination techniques.

- Camera parameters, such as brightness, exposure and gain, are automatically adjusted with a single slider
- Light intensity and camera settings are automatically synchronized
- Advanced user settings, such as shading, help to optimize stitching of images

## 2D / 3D STITCHING\*\*

Scan your region of interest quickly. Create 2D & 3D images using interactive scan points and orientation with the image navigator.

- 2D scan areas are defined using interactive scan points or the image navigator
- The LAS X.next graphical user interface guides you through image acquisition, measurements and reporting
- Directly open and view 3D scan images in the surface viewer

\* Measurement results depend on used objective, zoom and microscope settings.

\*\* Results depend on sample, used objective, zoom and microscope settings.

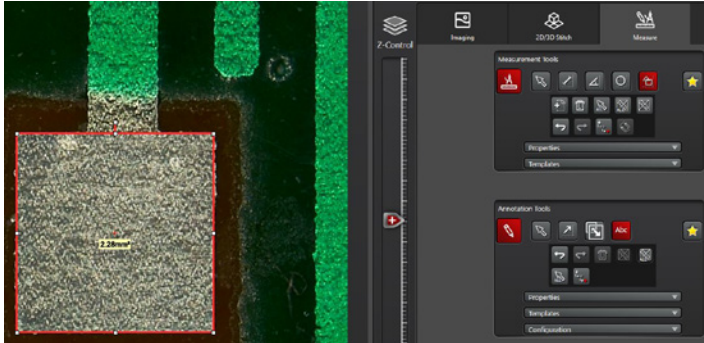

## MEASUREMENTS & ANNOTATIONS

Complete your workflow tasks with a streamlined process using measurement and annotation tools, favorite settings, and custom-defined templates.

- Select your favorite, most used measurement tools
- Adapt and save your personal settings for both measurement and annotation tools
- Get reproducibility as your custom-made system settings can be saved and recalled

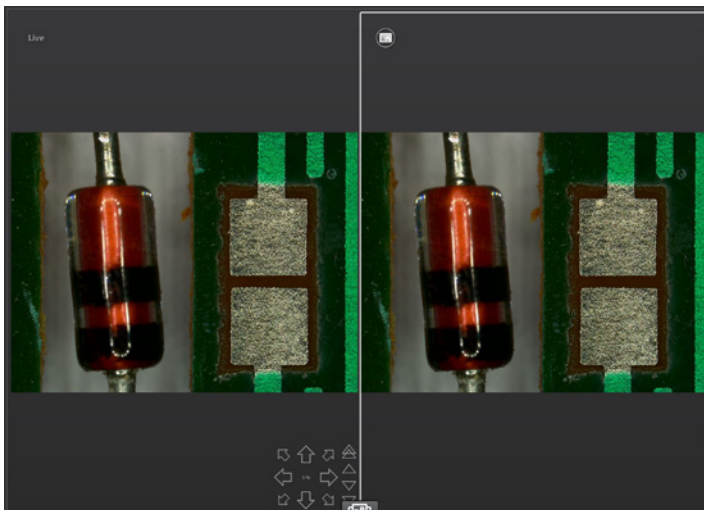

## RESULTS

Take advantage of the results tab to review, edit, and make final changes to your captured images using the interactive image gallery. Once satisfied, generate and reproduce reports to share your results.

- Easy and fast browsing of images thanks to the efficient interface
- Compare up to 9 different images at one time
- Create a list of your favorite images with the ideal illumination settings and then apply them to quickly optimize new images

## EFFICIENT DOCUMENTATION

You can make 2D measurements, 3D analyses, and annotations on the image with the LAS X software. Export your results to an Excel report template with few clicks. You can rely on correct measurements for each image because the zoom and objective values are seamlessly displayed and the correct zoom calibration is automatically applied. Additionally, the total magnification is always saved and displayed with each image.

## ENCODED SYSTEM: MINIMIZE ERRORS

To help prevent errors, all critical functions of the DVM6 are monitored with sensors.

The encoded components include:

- XY-stage
- Focus drive
- XY-stage rotation, stepless adjustment from  $-180^\circ$  to  $+180^\circ$
- Tilting angle, continuous adjustment from  $-60^\circ$  to  $+60^\circ$
- Continuous magnification
- Objective type
- Illumination type and intensity
- Optional accessories

# FIND YOUR CONFIGURATION

To help you find the solution that best fits your application and budget needs, Leica Microsystems offers the DVM6 in different configurations.



## DVM6 A

- Motorized precision xy-stage with manual coarse positioning
- Motorized focus for automatic 3D image-stacking (can also be focused manually)
- Software package including image capture and management, 2D measurements and annotations, images with high depth of field, autofocus function, multi-focus images with 3D view and measurement, and automatic xy panoramas in 2D and 3D

## DVM6 M DIGITAL MICROSCOPE ZOOM MODULE

If your sample is too large or bulky for the standard DVM6 configuration, the modular DVM6 M offers you more flexibility for a wide range of applications in automotive and electronics industries, medical device manufacturing, forensics, and earth sciences.

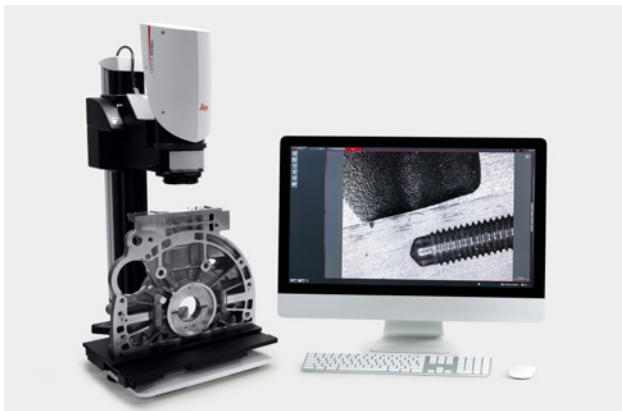

Inspection of large automotive parts



Quick in-line quality control for electronics production

With a special interface adapter, the DVM6 M zoom module can be used with selected stands from the Leica M series. This setup allows you to examine larger and higher samples.

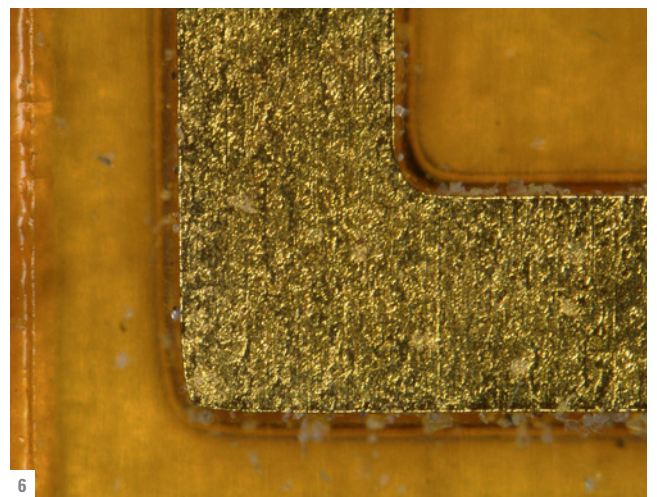
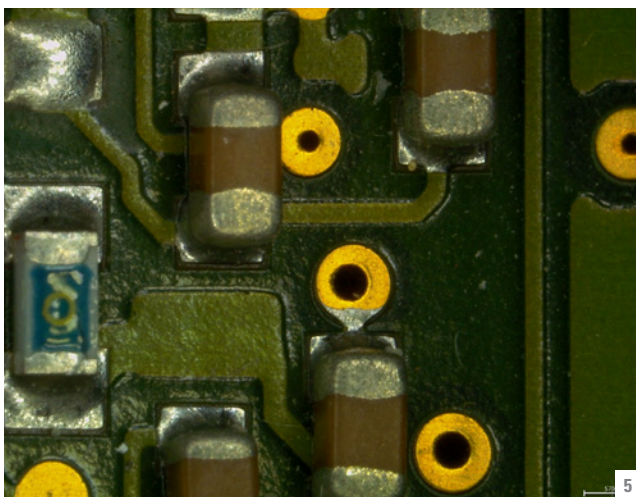
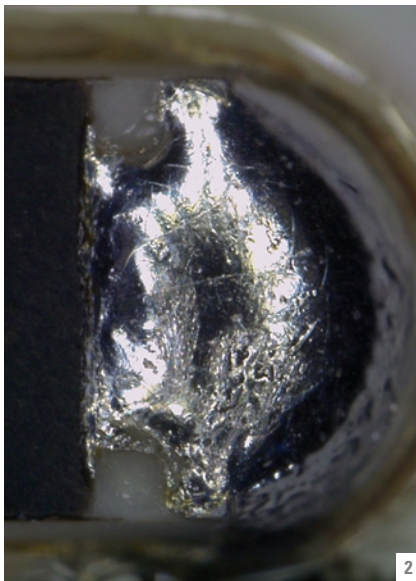
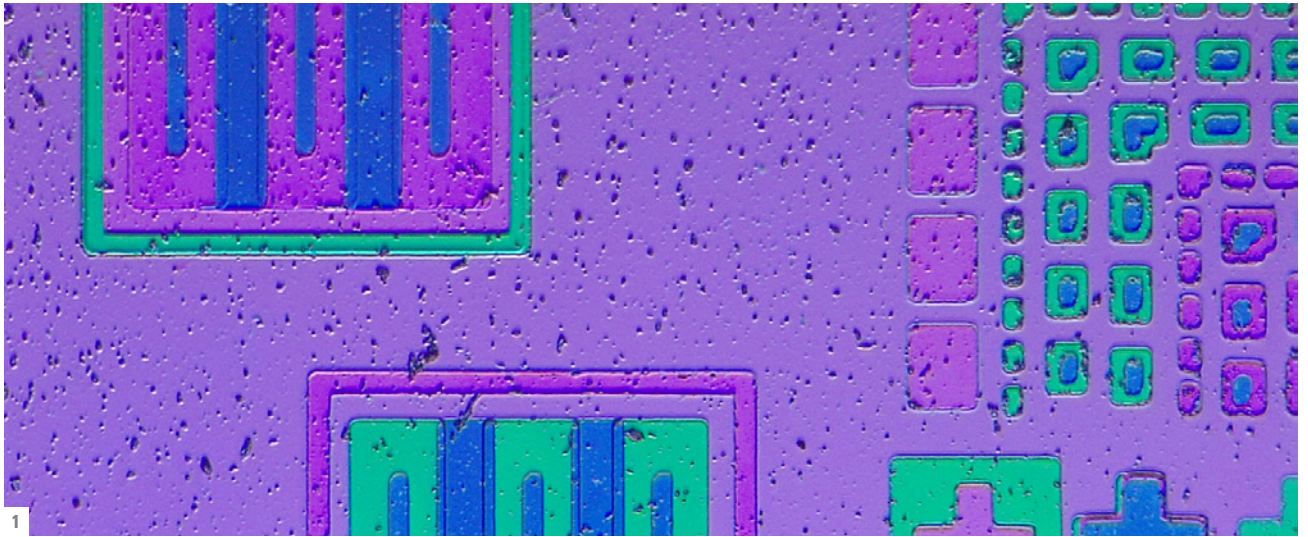

1: Wafer - 750x, coax open, relief contrast  
 2: Solderjoint - 175x, ringlight  
 3: Solderjoint - 175x, ringlight and diffusor

4: Filter grid - 200x, backlight  
 5: PCB - 70x, 14° tilted, ringlight  
 6: Bondpad - 360x, Au-plated, automotive electronics

# SAY YES TO THE DVM6 AND ...

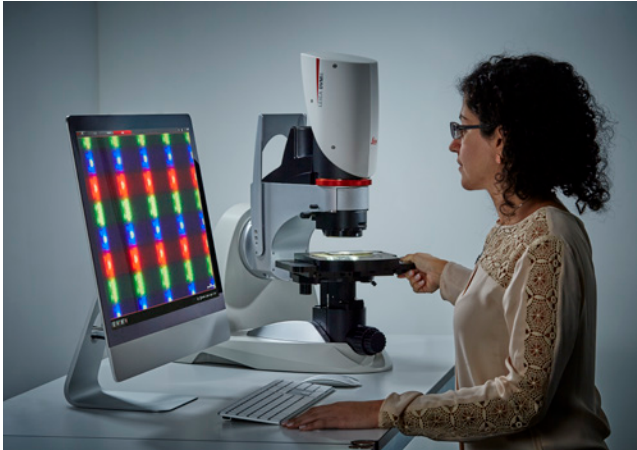

## ... BENEFIT FROM VERSATILITY

- Different configurations for individual application needs and budgets
- One single system to accommodate various sample types and sizes to 2 kg and travel range of 60 mm

## ... MAKE MICROSCOPY EASY

- Robust instrument easy to use
- Software features for recurring tasks assure same data quality from user to user
- Flexibility and suitable ergonomics for individual microscope work space arrangements



## ... OPTIMIZE REPORTING

- Reporting with preconfigured excel templates
- Reliable inspection results from user to user and sample to sample
- Reports with comprehensive analysis and measurements for 2D or 3D surfaces



## ... GET A SYSTEM SOLUTION THAT PAYS OFF

- Windows-based system, easy network integration, and compatible with most PC hardware brands
- Out-of-the-box solution, with only one power cord and USB cable and ready to run
- Minimal training requirements and training on the job is possible
- LAS X updates or additional software modules keep your system up-to-date

- 1: BGA Solderball with LAS X measurement in 2D and 3D
- 2: Cr-oxide - 280x, coaxial illumination
- 3: Leadframe - 13x
- 4: Detail plastic beverage packaging - 140x

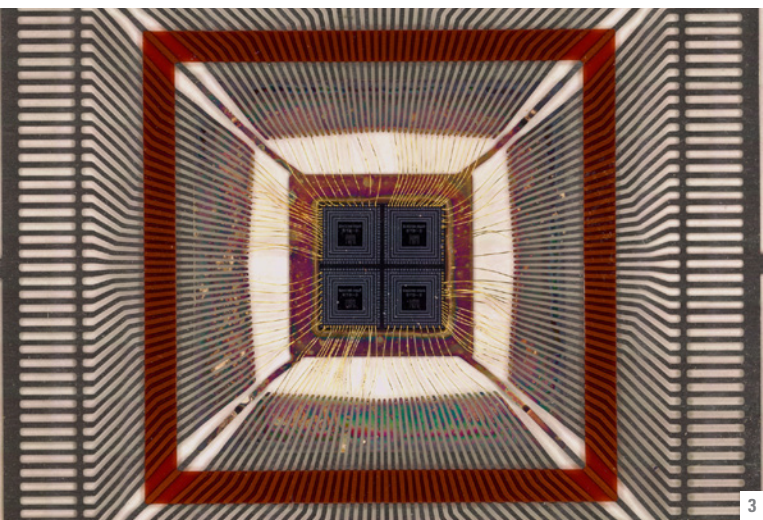
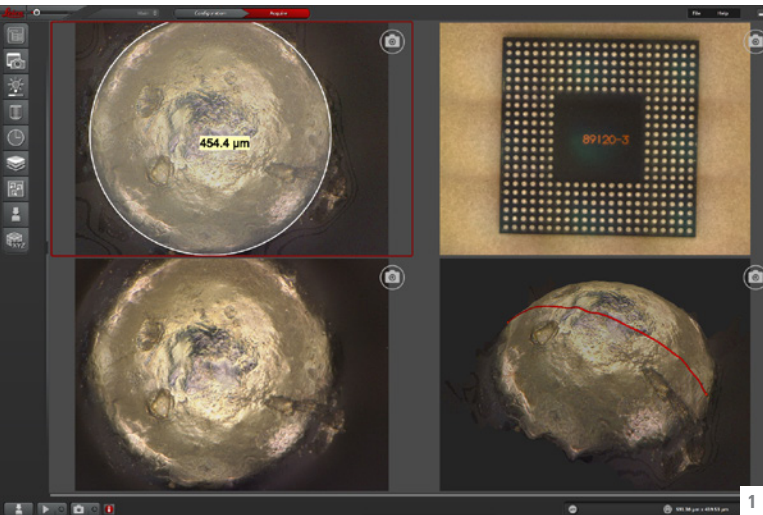

# SYSTEM OVERVIEW AND SPECIFICATIONS



## DIMENSIONS

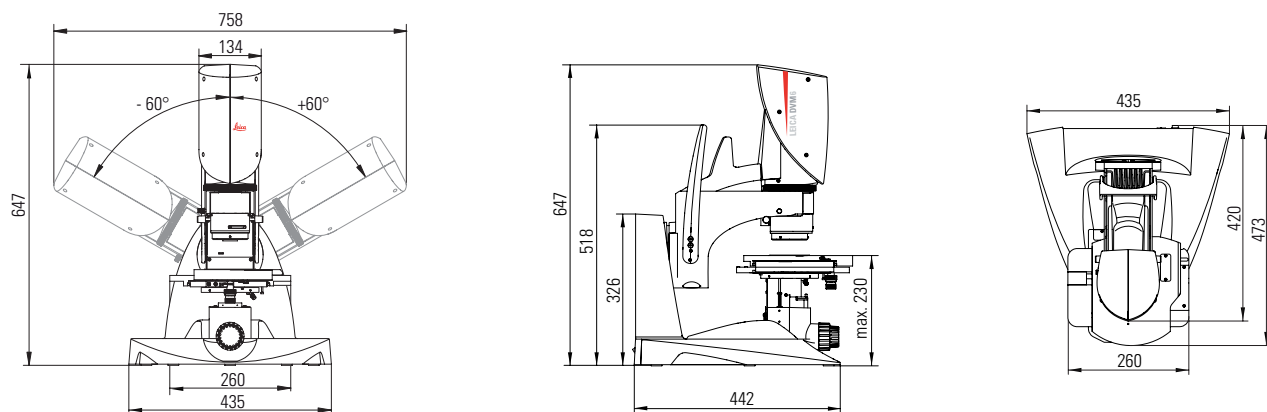

Dimensions in mm

**SYSTEM****DVM6 A****CONFIGURATION**

advanced, motorized focus drive and motorized xy-stage

DVM6 zoom module	✓
Tilting stand	✓
XY-stage	✓
Focus drive	✓
<b>LAS X SOFTWARE</b>	
Parameter recall	✓
HDR	✓
Image preview	✓
Autofocus	✓
Multifocus images	✓
3D surface image	✓
XY-stitching	✓
XYZ-stitching	✓
Annotations	✓
2D Measurement (distance, area, angle)	✓
3D Measurement (distance, area, angle, profile, volume)	✓

**ZOOM MODULE**

Camera	image sensor	1/2.3" CMOS, 3664 x 2748 Pixel
	image resolution	2MP (1600 x 1200)
		5MP (2592 x 1944)
		10MP (3664 x 2748)
framerate (max)	37 fps @ 1600 x 1200 live image	
Autofocus	sensor	CMOS based sensor
	options	local or global
	modes	single autofocus, continuous autofocus
Iris diaphragm	motorized, software controlled	

**OBJECTIVES (according ISO 18221)**

PlanAPO FOV 43.75	working distance: 60 mm	max. magnification: 190:1	max. resolution: 415 lp/mm
PlanAPO FOV 12.55	working distance: 33 mm	max. magnification: 675:1	max. resolution: 1073 lp/mm
PlanAPO FOV 3.60	working distance: 5 mm	max. magnification: 2350:1	max. resolution: 2366 lp/mm

**TILTING STAND**

Tilt angle	max. ± 60°	tilt angle encoded and displayed
Handling	one handed (weight compensation)	
	0° index for home position	

**XY-STAGE**

Travel range	70 mm x 50 mm
Resolution	1 µm
Rotation	max. ± 180°
Specimen weight (max load)	max. 2 kg

**FOCUS DRIVE**

Travel range	60 mm
Resolution	0.25 µm (motorized)
	0.50 µm (manual)

**ILLUMINATION**

Ringlight	integrated in objectives for the DVM6
	LED light source, software controlled
	4 segments switchable
Coaxial light	integrated in tilting stand, available for FOV 12.55 & FOV 3.60 objectives
	LED light source, software controlled
Transmitted light	cable-free insert for xy-stage (optional)
	LED light source, software controlled

**OPTIONAL ACCESSORIES**

Ringlight adapters	diffuser
	low angle adapter
	polarizer
BLI for DVM6	transmitted light insert on xy-stage
Hand-/foot switch	
Interface module	connect DVM6 zoom module to Leica (M series) focus column
Travel case	

## THE DVM6 DIGITAL MICROSCOPE

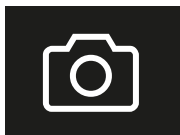

### 10 MEGAPIXEL CAMERA

- Fast live images
- High-resolution capture

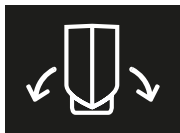

### EASY TILTING

- One handed operation for improved ergonomoy
- Simple and quick change of perspective



### PLANAPO OPTICS

- Magnification flexibility with 16:1 zoom range
- Image calibrated in every position

**DON'T SEARCH. FIND!**