

Ultrapure Water System
HALIOS





HALIOS lab water systems are designed to enhance your efficiency, ensuring a more enjoyable workflow while optimizing your lab's productivity.



The HALIOS Lab Water Series features a modular design, providing exceptional flexibility to accommodate specific requirements.

Each system exceeds ASTM Type 1 standards, delivering reliable, high-quality performance.

An integrated pre-treatment system ensures consistent and reproducible analytical results.

The external tabletop dispenser allows for streamlined operation, while the compact production unit integrates efficiently into any lab environment.

Features

- ✓ Reliable ultrapure water quality - ASTM type 1+
- ✓ External dispenser
 - ❖ detachable and ergonomically shaped
 - ❖ rotatable and vertically adjustable
- ✓ Simple and economical change of the consumables
- ✓ Large and intuitive touchscreen
- ✓ Leak water detector
- ✓ Pressure reducer
- ✓ Data capture via USB
- ✓ Accurate, adjustable volume dispensing
- ✓ Dry-run protection
- ✓ Simple disinfection procedure
- ✓ Pressure and flow sensor
- ✓ Plug and Use – All consumables and installation material are included
- ✓ Note on the replacement of all consumables (no obligation to replace)
- ✓ Complete recirculation ensures the highest microbial purity
- ✓ Warnings and notes in clear text
- ✓ Alarm history
- ✓ UV-unit (185|254nm) for the ultimate microbiological purity and TOC reduction
- ✓ 100% Made in Germany
- 🌱 ECO Mode to extend the cartridge life by up to 20%



System configuration

- Wide-range power supply 80-264V / 50-60Hz
- Housing with an easily accessible service cover
- Compact production unit fits easily into various free spaces in the lab
- Exchange of consumables within seconds due to quick-connect couplings
- Integrated pressure reducer for different inlet pressures
- Flow meter for an accurate volume dispensing
- Pressure sensor for monitoring of the working pressure and as a dry-running protection
- Low-noise and durable recirculation pump for the complete internal recirculation of all wetted parts up to the final dispensing valve
- Integrated pre-treatment cartridge protects from impurities in the feedwater and guarantees reproducible results of analysis, a high capacity and low operating costs
- Ultrapure water cartridge for the final removal of organics and remaining ions
- Up to four measuring cells for the exact measurement of the conductivity and temperature after each purification cartridge
- Flush valve for the effective cleaning of all wetted parts as well as an adjustable quality flush during stand-by
- Dispenser with microfiltration for the sterile ultrapure water withdrawal at the point of use
- Wall brackets for production unit and dispenser
- Dual wavelength UV disinfection for lowest TOC values



Various options to adapt to your specific needs:

- Flushed and integrated ultrafiltration module for the retention of pyrogens, endotoxins, proteins, and nucleases (DNases and RNases)
- Real-time TOC monitor for the continuous TOC measurement of the organic compound acc. to USP
- Up to 4 external dispensers can be connected to one production unit
- Additional conductivity cell to monitor the feedwater quality
- Potential-free contact for collective error signal
- XXL dispenser (height +15cm) for even more space underneath the dispensing handle
- Qualification documents

User interface

- Large and intuitive touchscreen
- Multilingual interface
- Stored dispensing reports with all information ensure an absolute traceability of the water withdrawals
- Individual adjustment for displaying the conductivity (M Ω cm or μ S/cm)
- Multilevel conductivity and temperature monitoring for pure and ultrapure water, temperature compensated with stepless limit adjustments
- High-precision measuring with integrated reference resistors as well as deactivatable temperature compensation acc. to USP
- Leakage monitors with error message and automatic shut-off of the feed water supply
- Continuous surveillance of all relevant parameters and values incl. early reminders when a change of consumables is pending
- GLP-compliant data storage via USB
- ECO Mode to extend the cartridge life by up to 20%, reducing operating costs



Tabletop dispenser

- Ergonomic design for a one-handed operation
- All dosing functions can be easily executed with the rotary encoder at the dispensing handle
- The external dispenser can be placed independent of the production unit
- For an even greater range the HALIOS handle can be detached and reattached with a simple hand movement



Feed water requirements

Feed water quality	pretreated water (EDI, DI, RO or distilled water)
Conductivity at 25°C	< 100µS/cm
Total organic carbon (TOC)	< 50ppb
Inlet pressure*	max. 6bar
Temperature	5 – 35°C

* At an inlet pressure between 0 - 0.2bar the system will operate, but the product flow rate may be lower.

Ultrapure water specifications (ASTM type 1)¹:

Resistivity (Conduct.) at 25°C ²	18.2MΩcm (0.055µS/cm)
Total Organic Carbon ³ (TOC)	≤ 2ppb (µg/l)
Particle content ⁴	< 1/ml
Bacteria	< 0,01 CFU/ml ⁴ < 0,005 CFU/ml ⁵
Pyrogens (endotoxins) ⁵	< 0,001 EU/ml
RNases ⁵	< 0,004ng/ml
DNases ⁵	< 0,024pg/µl
Flow rate	Up to 2l/min

¹ The actual values may vary depending on the nature and concentration of the contaminants in the feed water.

² Conductivity/resistivity can also be displayed non-temperature compensated as required by USP

³ In the appropriate operating conditions

⁴ With sterile filter capsule at the POU

⁵ With option – ultrafiltration module

Technical data

Ambient temperature	+2 - 35°C
Supply voltage	90-240V / 50-60Hz
Connected load	120W
Connection size	R ¾"
Weight – Production Unit	15kg
Weight – Tabletop Dispenser	7kg

Dimensions

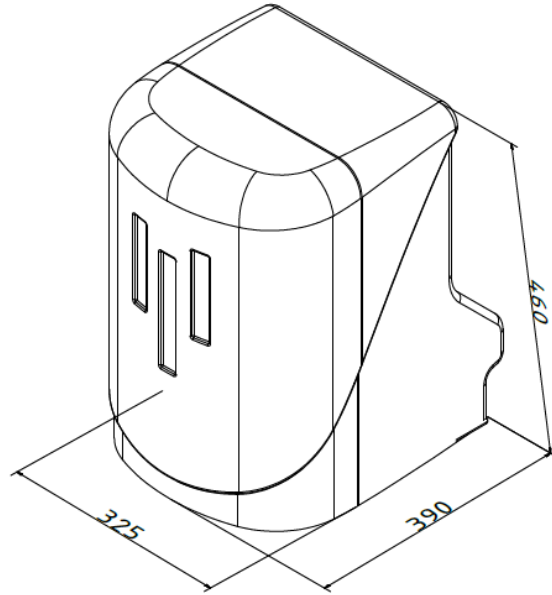
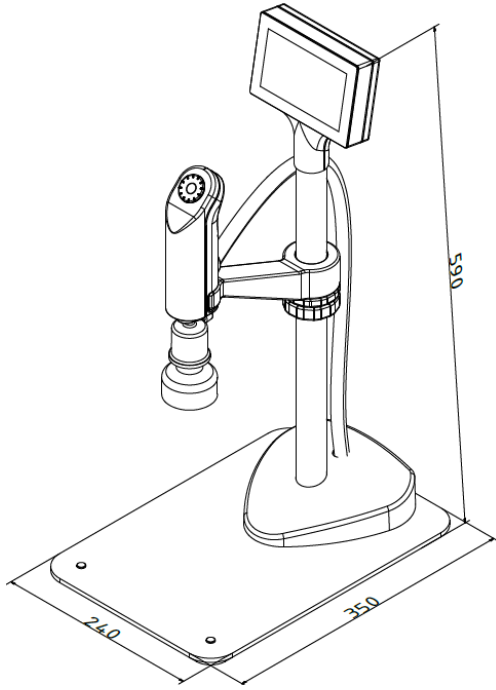



Altium International Sp. z o.o.
ul. Puławska 303, 02-785 Warszawa
telefon +48 22 549 14 00
klient.pl@altium.net
www.perlan.com.pl
www.altium.net

