

# Agilent NovoCyte Penteon, NovoCyte Quanteon, and NovoCyte Advanteon

When exceptional performance meets simplicity



# A Quantum Leap In Benchtop Flow Cytometry

The Agilent NovoCyte Penteon, NovoCyte Quanteon, and NovoCyte Advanteon

The NovoCyte Penteon, NovoCyte Quanteon, and NovoCyte Advanteon flow cytometers build on its successful predecessor, the NovoCyte, to provide an expanded set of capabilities that accommodate today's high-end and increasingly sophisticated multi-color flow cytometry assays. You now have the flexibility to choose from up to 30 fluorescence channels utilizing up to 5 lasers with up to 30 independent detectors. The NovoSampler Q, which can be integrated into different laboratory automation platforms, efficiently processes both FACS tubes (using a 40-tube rack) and 24-, 48-, 96-, and 384-well plates. The intuitive and industry-leading NovoExpress software has been further advanced, providing an exceptional user experience in data acquisition, analysis and reporting.



- Expanded flexibility with up to 30-color options using up to 5 lasers
- High-sensitivity and resolution
- Intuitive and powerful software for data acquisition, analysis, and reporting
- Smart-design functionalities and walk-away operation to simplify your workflow
- Automation-ready capability for high-throughput needs
- Wide, 7-log dynamic range eliminates the need for routine detector adjustments

# The Sensitivity You Demand

Silicon Photomultiplier (SiPM) – The ultimate photodetector

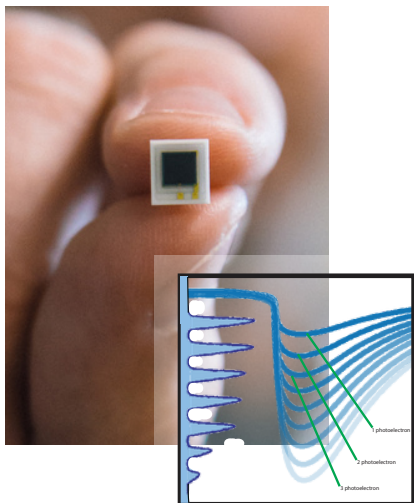

## What is a SiPM?

Silicon photomultipliers (SiPM) are solid-state, semiconductor devices. Consisting of a compact array of avalanche photodiodes operating in unison, SiPM is a detector with photon counting capability. An innovative optical design in the NovoCyte Penteon, NovoCyte Quanteon, and NovoCyte Advanteon incorporates up to 30 independent SiPM for collecting and processing signals for each of its fluorescence channels.

This high-sensitive detector provides more confidence so you can detect even the dimmest signals in your sample.

## SiPM's strengths:

- Photon detection sensitivity
- High-gain and high-quantum efficiency
- Instantaneous warm-up and fast response
- Robust and long lifespan
- High-durability

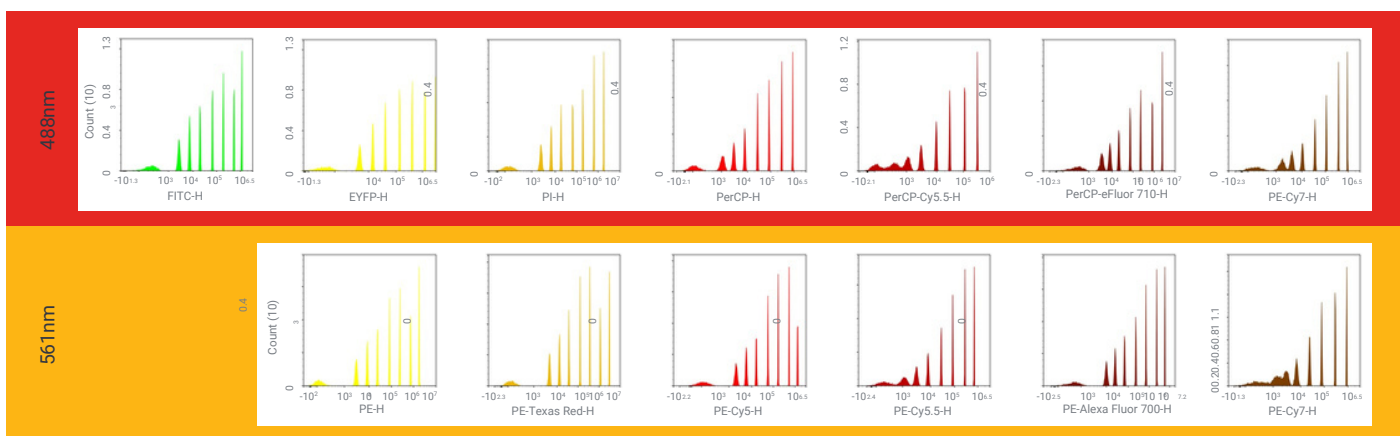

## FSC/SSC detection resolution

NovoCyte Penteon, NovoCyte Quanteon, and NovoCyte Advanteon FSC/SSC detection optics and signal processing electronics have been optimized to resolve particles as small as 0.1  $\mu\text{m}$ . With this high-resolution, platelets, bacteria, and various sub-micron particles can be readily identified and analyzed.

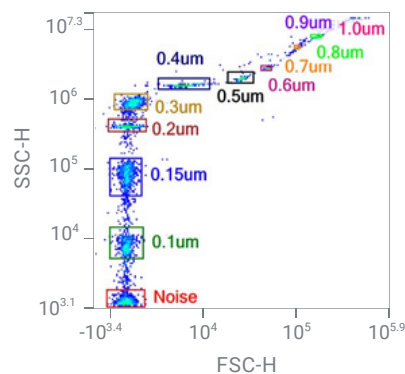

## Confidently quantify fluorescence signals

The optical and electronic subsystems are the result of state-of-the-art engineering. This design enables the NovoCyte Penteon, NovoCyte Quanteon, and NovoCyte Advanteon to deliver a highly linear detection signal response for all channels across a wide dynamic range.

To demonstrate the detection linearity, Chicken Erythrocyte Nuclei (CEN) ploidy was measured in relation to the mean fluorescence intensity of Propidium Iodide (PI) staining.

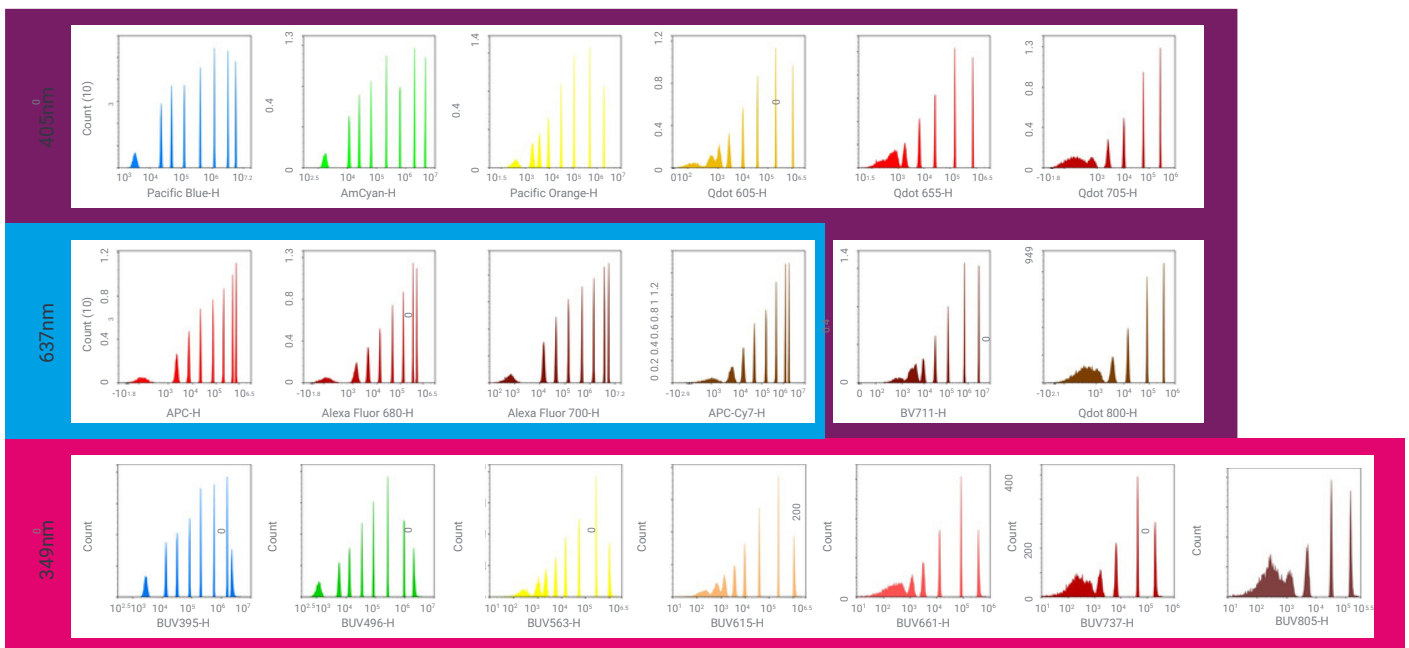
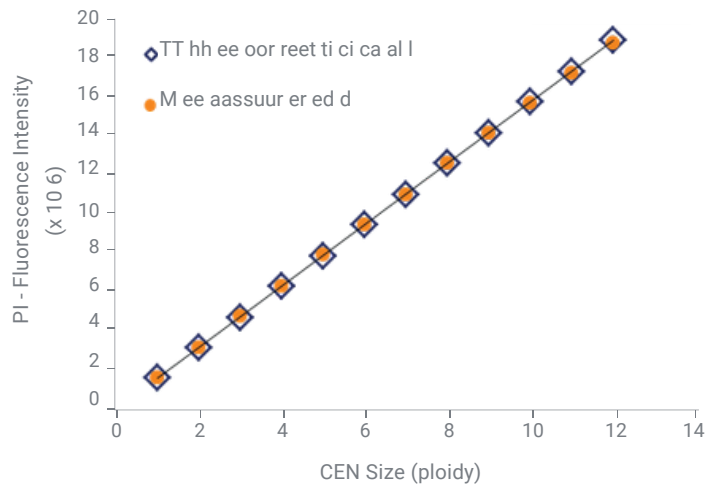

# Expand Your Capabilities

Comprehensive 24-color immunocell phenotyping panel in peripheral human blood

A human immune cell panel was run on the NovoCyte Penteon identifying all major immune cell subsets in human peripheral blood including T cells, B Cells, natural killer (NK) cells, monocytes, and dendritic cells. Included in this panel were markers for T cell functional chemokine receptors and activation markers, which facilitates further in-depth characterization of T cells.

Equipped with up to 30 fluorescence channels from up to five lasers (349, 405, 488, 561, and 637 nm) the NovoCyte Penteon, NovoCyte Quanteon, and NovoCyte Advanteon offer tremendous flexibility in panel design. Optimized detector settings eliminate the need for complicated and laborious adjustments, making data acquisition as simple as load-and-go.

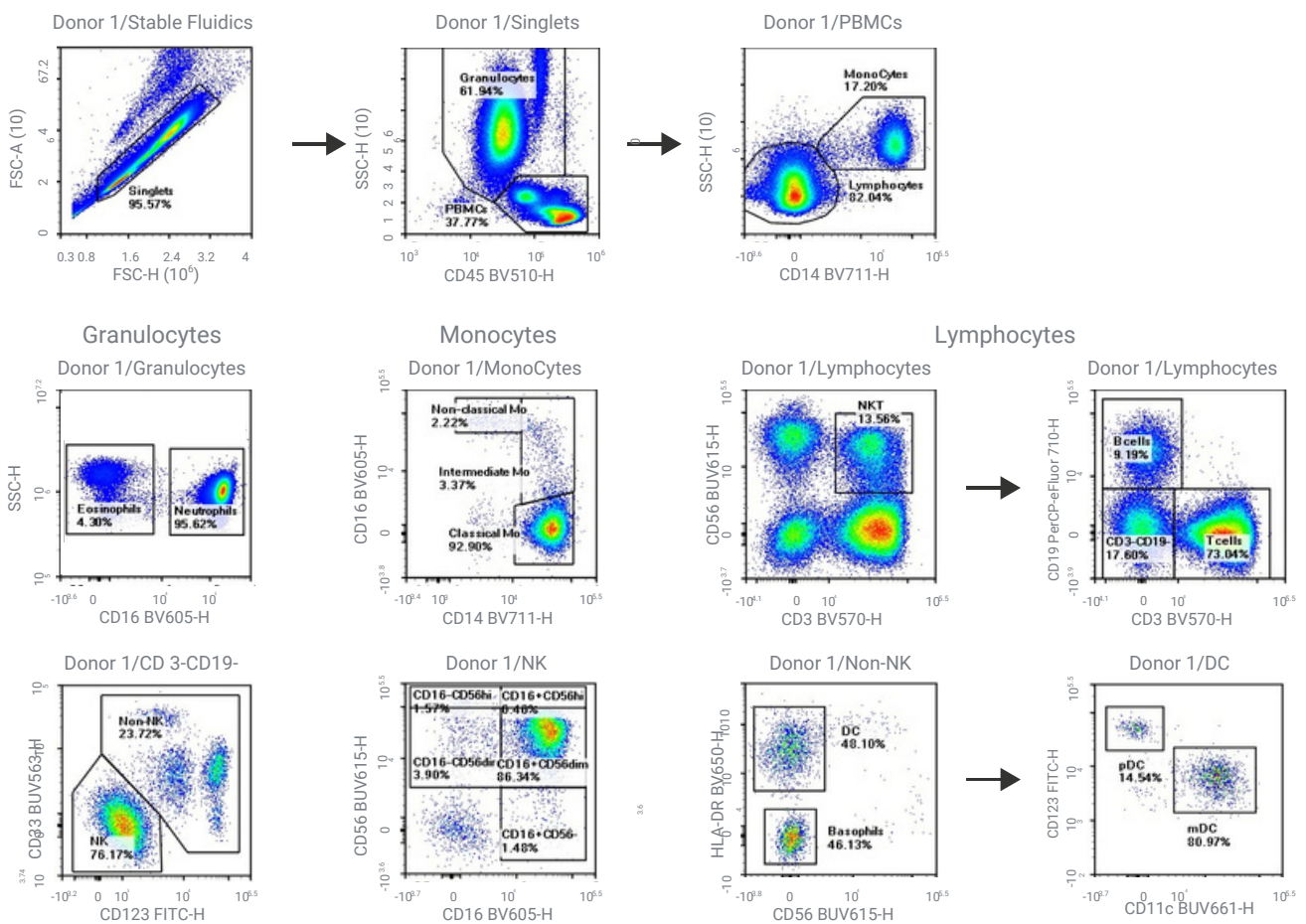

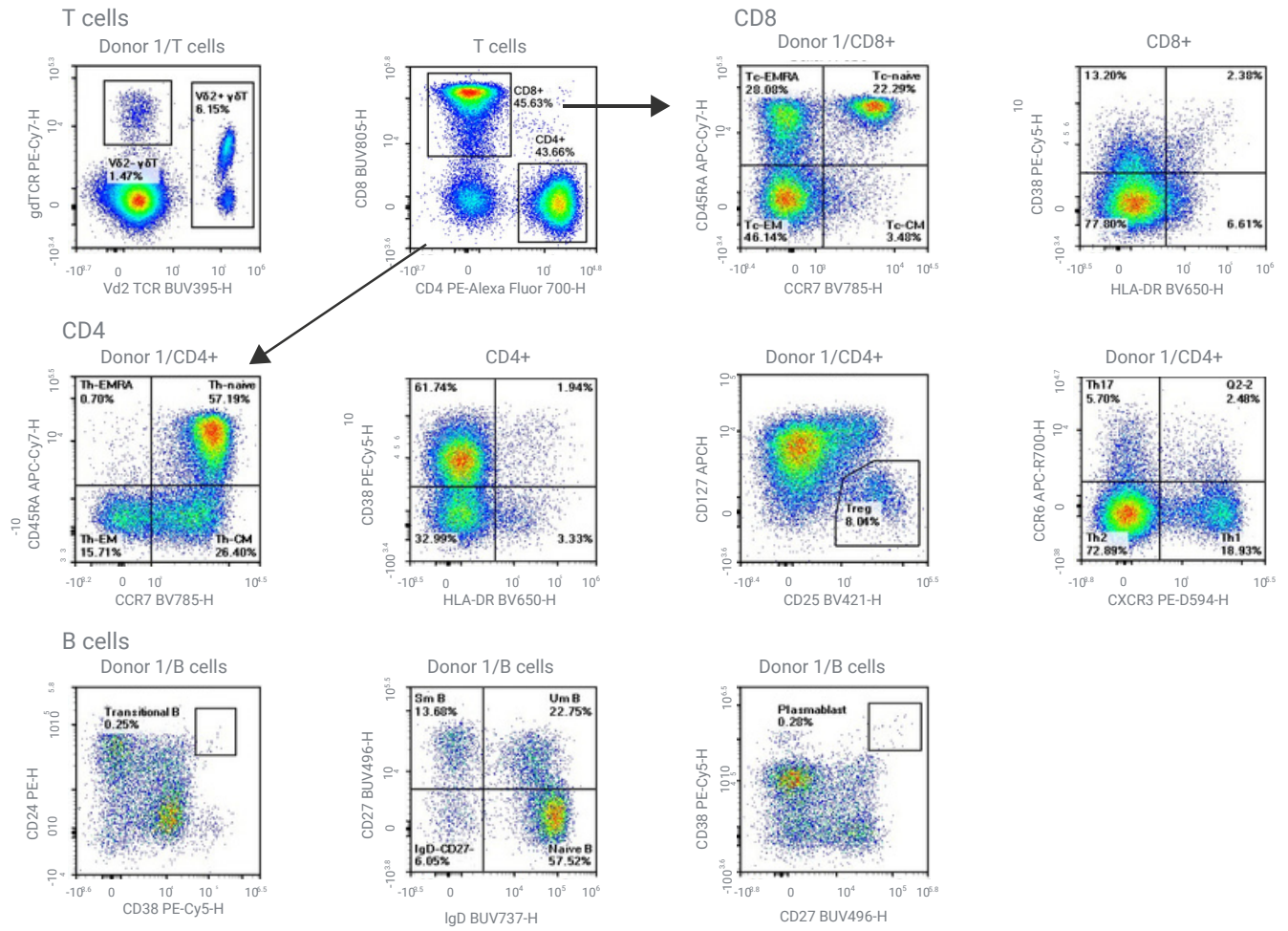
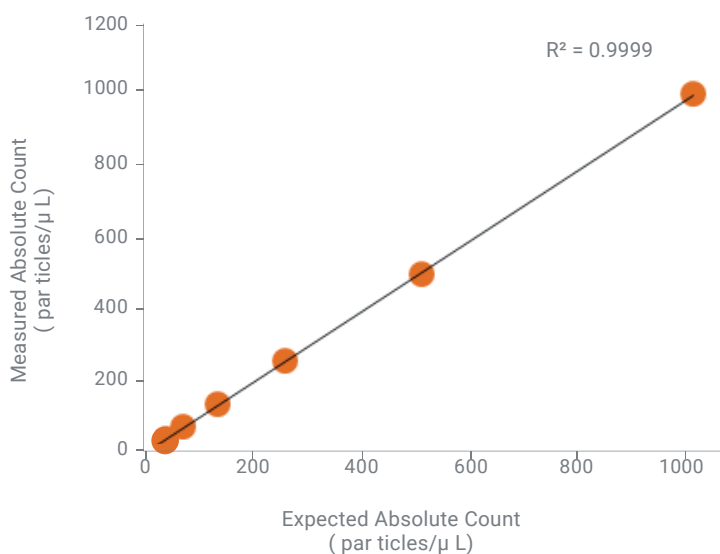

Figure 1 Legend: Identification of immune cells in peripheral human blood with a 24-color immunophenotyping panel on the NovoCyte Pentecent. Whole blood was stained with Vδ2 TCR-BUV395, CD27-BUV496, CD33-BUV563, CD56-BUV615, CD11c-BUV661, IgD-BUV737, CD8-BUV805, CD25-BV421, CD45-BV510, CD3-BV570, CD16-BV605, HLA-DR-BV650, CD14-BV711, CCR7-BV785, CD123-FITC, CD19-PerCP-eF710, CD24-PE, CXCR3-PE-Dazzle 594, CD38-PE-Cy5, CD4-PE-AF700, γδ TCR-PE-CY7, CD127-APC, CCR6-APC-R700, CD45RA-APC-Cy7 antibodies. After staining, samples were acquired on the NovoCyte Pentecent and analyze on NovoExpress. Hierarchical gating was used to identify all major cell subsets in human blood.

## Direct absolute cell count makes reference beads obsolete

NovoCyte Penteon, NovoCyte Quanteon, and NovoCyte Advanteon use a high-accuracy syringe pump to directly drive the sample and provide accurate, absolute count results in every run. Why use reference beads when you don't need them?

- The volumetric absolute count is determined for each and every sample automatically
- Complicated calibration of the fluidics system is not required
- Expensive reference beads are not required



## NovoCyte Instrument Configurations

- For more information on NovoCyte instruments, please visit [www.agilent.com/chem/novocyte](http://www.agilent.com/chem/novocyte)

Product	Lasers	349 nm	405 nm	488 nm	561 nm	637 nm	Maximum Number of Fluorescence Channels
NovoCyte Advanteon**	1			●			7
					●		6
	2		●	●			15
				●	●		13
				●		●	11
	3		●	●	●		21
				●	●	●	17
		●	●		●	19	
NovoCyte Quanteon**	4		●	●	●	●	25
NovoCyte Penteon*	5	●	●	●	●	●	30

\* RUO: Research use only. Not for use in diagnostic procedures.

\*\* Selected configurations are registered as CE-IVD.

# Walk-away Automation Simplifies Your Workflow

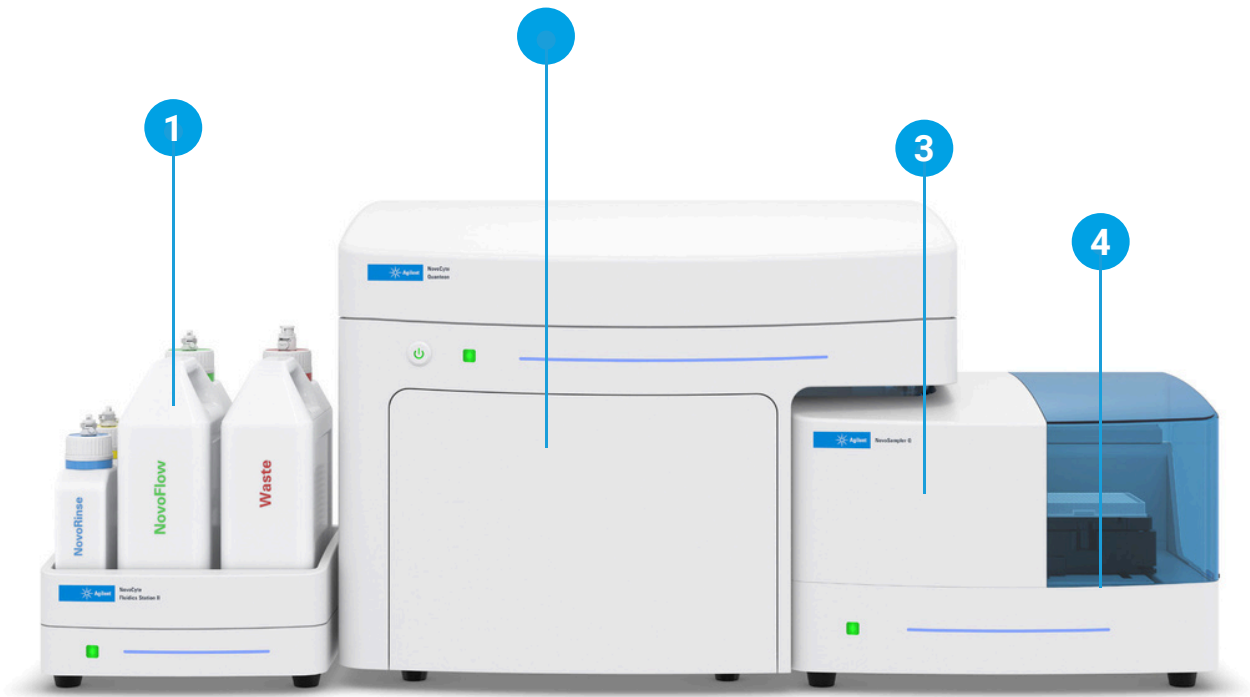

## 1) Continuously monitors fluid levels

A fluidic station will sense low sheath fluid or high-waste and eliminates the need for manual inspection. Fluidics consumption is estimated before a plate runs to ensure uninterrupted sample acquisition.

## 2) Easy startup and shut down

Quick startup with automated fluidic rinsing takes only minutes to prepare the instrument for your daily use. The configurable pre-scheduled shutdown thoroughly cleans at a specified time each day to eliminate the hassle of end of day manual cleaning with an automatic shutdown cleaning procedure.

## 3) Embedded quality control

Quickly run daily QC, automatically generate comprehensive QC reports, and conveniently track performance over time with Levey-Jennings plots. The automatic QC test ensures proper performance monitoring not only day-to-day, but also over long-term use.

## 4) Hassle-free fluidics

Electronically monitored valves and sensors allow for automatic clog detection and recovery. A feedback control system continuously manages the sheath flow rate to maintain exceptional stability.

## “Smart” optical filters

The instrument will automatically recognize the optical filters and ensure the correct configuration. Once a filter is inserted, the software will recognize the change, and report a misplacement. The filter recognition software tool ensures a properly arranged optical configuration.

Correct configuration

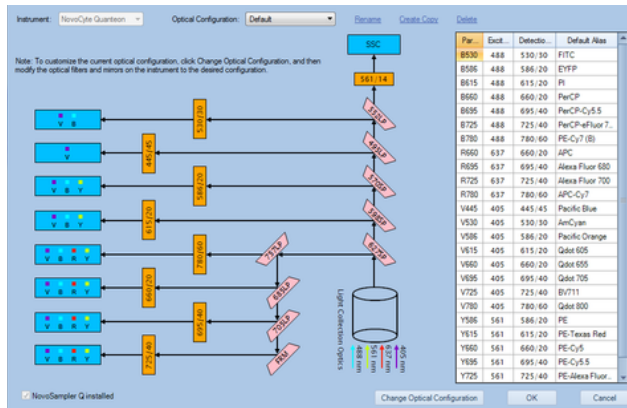

Incorrect configuration

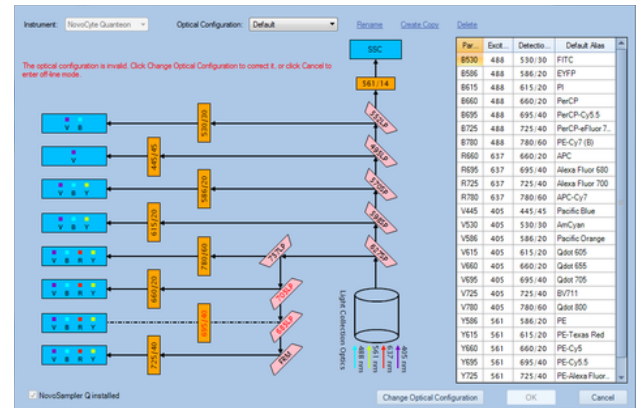
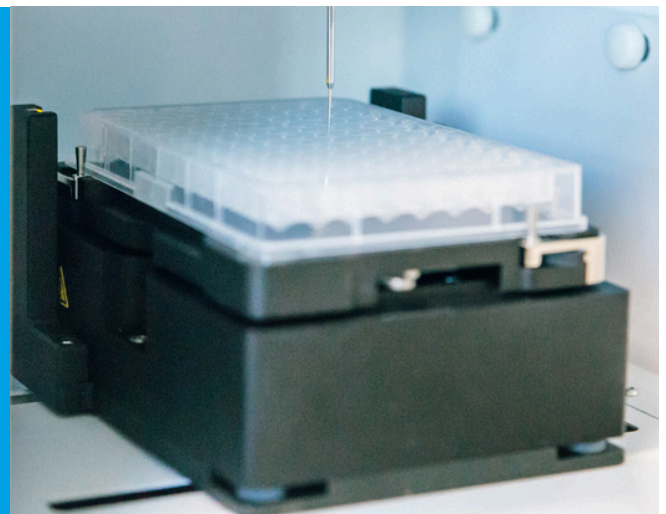

Figure 2. Optical configuration layout in the software shows interchangeable mirrors and filters with independent detectors for each fluorescence channel corresponding to different excitation lasers.

## Versatile sample injection probe (SIP)

- Tapered design minimizes dead volume
- Sample aspiration by syringe pump ensures precise absolute counting
- Automated SIP rinsing follows sample acquisition and minimizes cross-sample carryover
- Easy cleaning and maintenance
- Automated SIP collision detection and recovery



# A Flow Cytometer with Exceptional Reliability

Consistent results, reliable performance

NovoCyte Penteon, NovoCyte Quanteon, and NovoCyte Advanteon are equipped with high-quality lasers, optical filters, and detectors to ensure consistent signal detection. The fluidic feedback control mechanisms maintain steady flow conditions providing stability across a wide range of flow rates. The NovoCyte Penteon, NovoCyte Quanteon, or NovoCyte Advanteon are the flow cytometer you can rely on to provide consistent results under variable operating parameters.

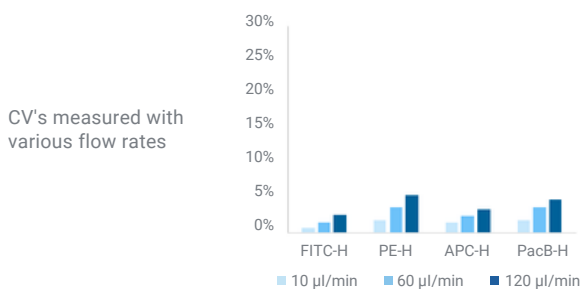
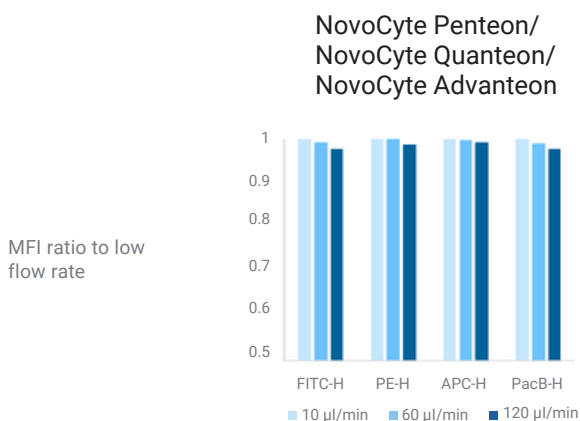

## Competitor

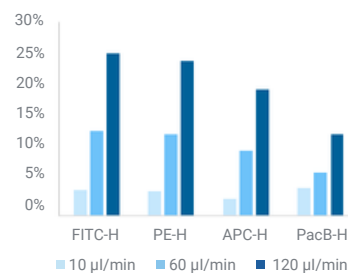
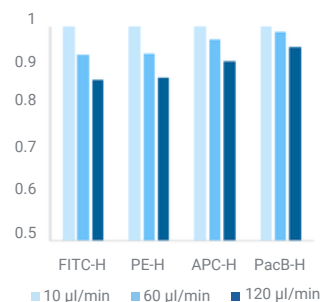

## High-reproducibility and stability

The NovoCyte Penteon, NovoCyte Quanteon, and NovoCyte Advanteon fluidic systems are designed to deliver high-performance. When compared to other flow cytometers, the fluidic consistency and stability of the NovoCyte Penteon and NovoCyte Quanteon are unmatched. Other instruments utilizing peristaltic pumps are often subject to fluidic pulsation, causing inconsistency and inaccuracy in absolute cell counts.

## NovoCyte Penteon/ NovoCyte Quanteon/ NovoCyte Advanteon

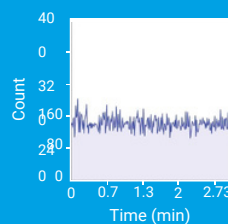

## Competitor

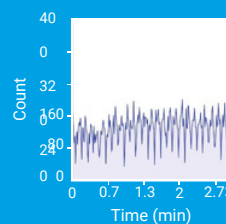

# Streamline Your Sample Acquisition and Data Analysis with the NovoExpress Software

Improved versatility and ease of operation

- One software interface for all: combining sample acquisition and data analysis
- Analyze acquired data in real-time during flow experiment to maximize productivity and efficiency
- Customizable statistical parameters with live updates when running samples
- Powerful compensation tools and convenient adjustments allow accurate pre-and post-acquisition compensation
- Batch analysis and reporting
- Easily create publication-quality figures with customizable plot scale, font, and legend
- Export as FCS (3.0, 3.1) or CSV files, import FCS files for analysis



Figure 3. Instrument toolbar showing quick access to QC and fluidic maintenance functions.

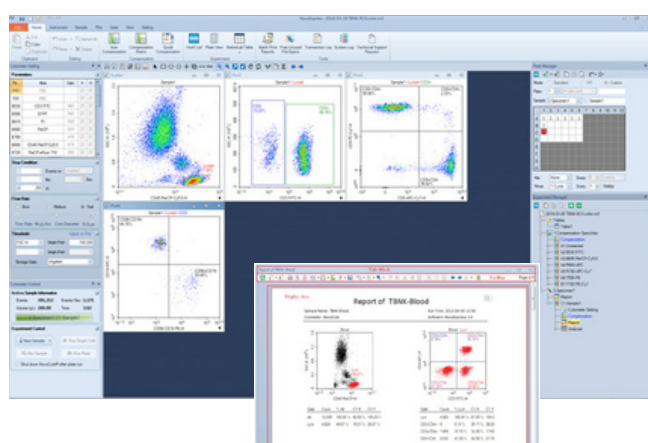
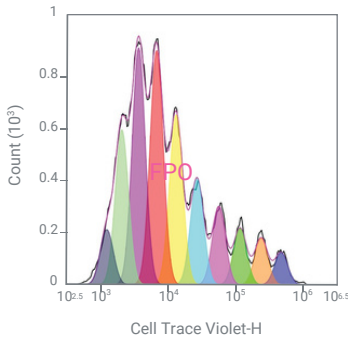

Figure 4. NovoExpress user-friendly interface for easy access to settings, analysis, reports, and plates/sample layout.

“This software is straightforward, and the software interface is easy to handle. The implemented auto compensation and a hierarchic tree structure is a highlight for effective organization of experimental data.”

- Matthias Schiemann, Technische Universität München

# Advanced Data Analysis is Made Easy with NovoExpress



## Cell proliferation modeling

Automatic analysis of cell proliferation to quickly identify generations of cell division and calculate the proliferation index for easy quantitation.

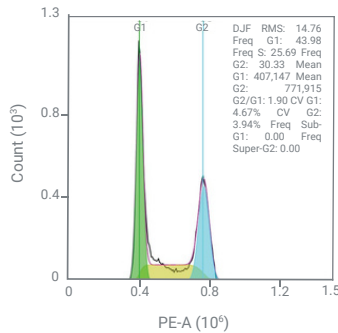

## New cell cycle analysis module

Dean Jett Fox (DJF) and Watson Pragmatic algorithms are both incorporated in the NovoExpress cell cycle analysis module. This provides additional flexibility for your cell cycle analysis and quantitation of G1, S, and G2/M transitions, as well as other parameters such as CV's and G2/G1 ratio.

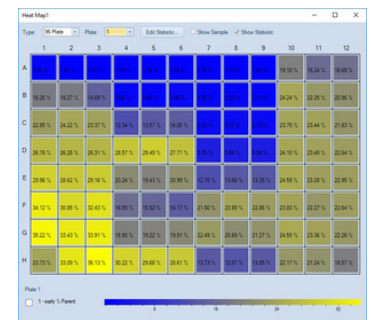

## Heat-map

The color representation of user-defined parameters allow quick visualization and comparison of many samples simultaneously.

The industry-leading NovoExpress software allows intuitive data acquisition, data analysis, and report generation. It provides flexible analysis templates and plotting tools, offering enhanced data analysis efficiency. Multitask and analyze sample data while simultaneously acquiring your remaining samples to maximize your productivity.

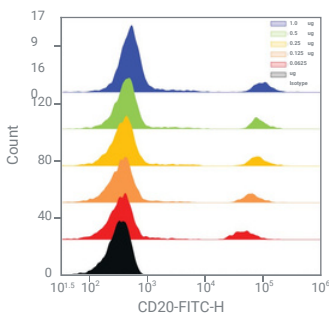

Histogram overlay (half-offset)

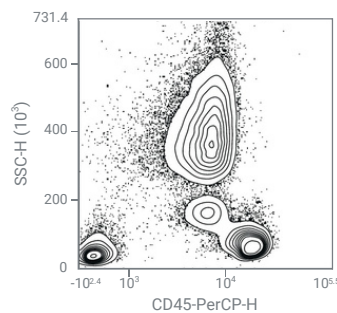

Contour plot with outliers

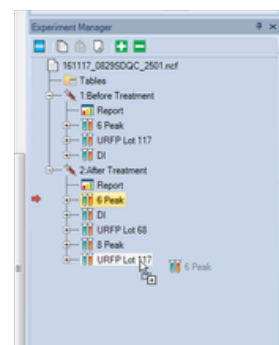

Drag-and-drop functionality to copy settings/analysis

# Automate Sample Loading For Your Versatile Sampling Needs

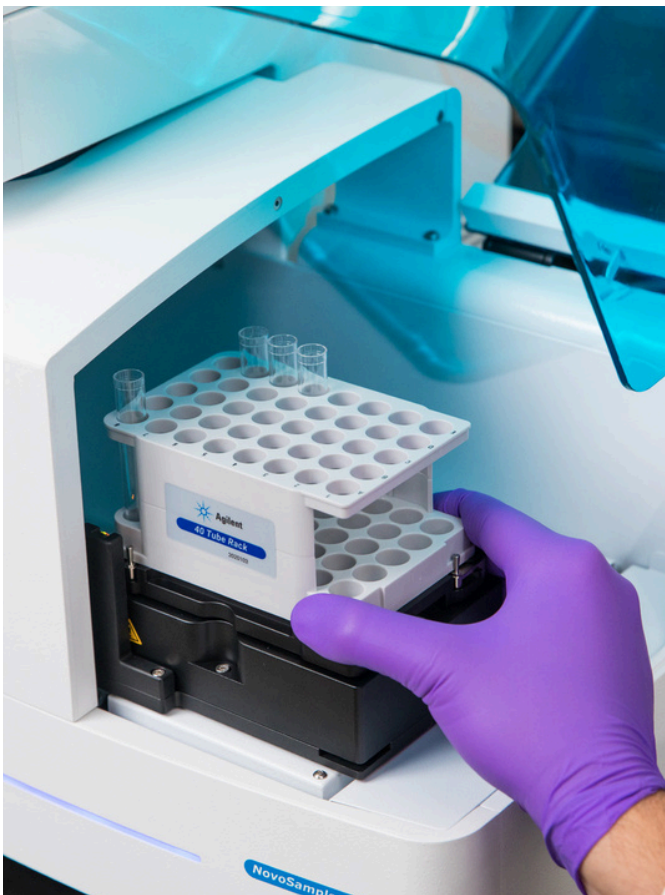
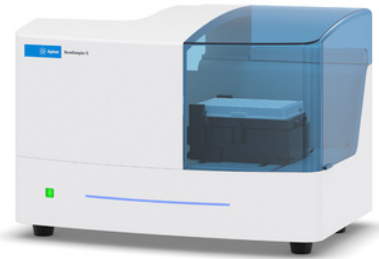

## The NovoSampler Q

The NovoSampler Q is an automatic sample loading system for high-throughput and automated sample acquisition. Seamlessly integrated with the NovoCyte Penteon, NovoCyte Quanteon, and NovoCyte Advanteon flow cytometers, the NovoSampler Q is easy to operate, delivering high-speed analysis and processing performance.

- Automated plate calibration eliminates the needs for manual alignment and calibration
- Versatile loading mode and increased throughput using various sample formats (40-tube rack, 96/384 well plates) including customizable plates
- Rapid and high-throughput reading as fast as under 20 minutes for a 96-well plate and under 80 minutes for a 384-well plate
- Lab automation-friendly with an open architecture and developer-ready API
- Reliable orbital shaking keeps samples in suspension throughout the process

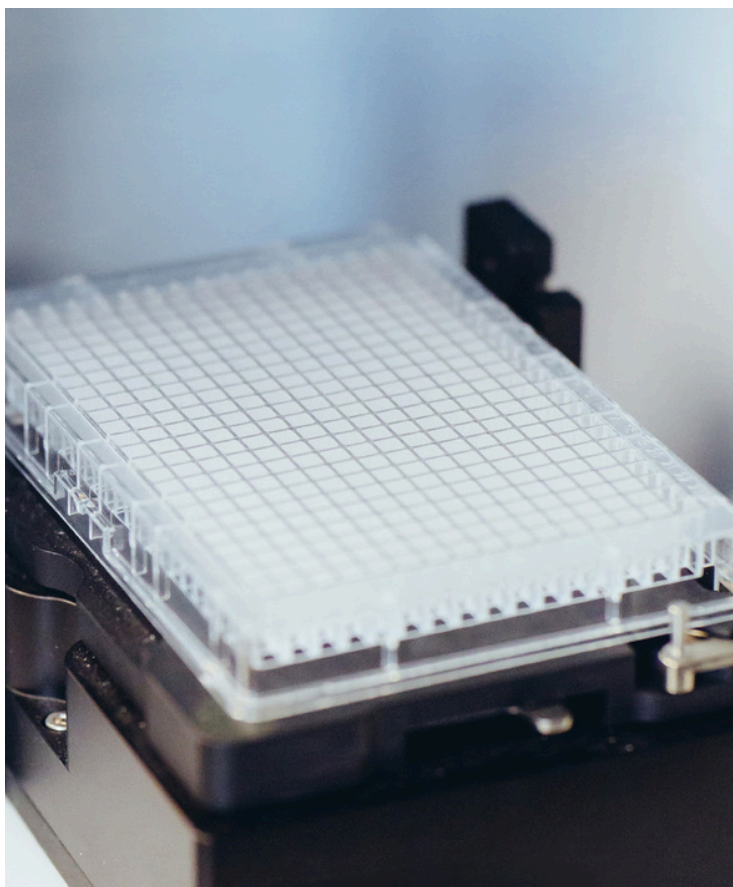

### Minimize sample carryover

A wide range of flow cytometry applications requires sequential processing and quantitative analysis of sample groups. Minimizing sample carryover is important when acquiring multiple samples and during the analysis of rare events. Carryover from previous samples can substantially affect rare event detection. An automated fluidics system eliminates manual intervention and allows for less than 0.1% sample carryover.

### Barcode for rapid sample ID and tracking

The barcode reader automatically and instantaneously identifies plate information in high-throughput experiments.

### Flexible run time

Maximize your productivity with optional large sheath and large waste fluid containers that allow extended sample processing capabilities before replenishment. Up to 15 L of waste capacity ensures continuous instrument operation with large sample batches.

### Uniform mixing ensures high-reproducibility

The NovoSampler Q ensures thorough sample mixing with default parameter settings and customized options. Easily adjust the mixing speed, duration, and acceleration to optimize mixing efficiency for your sample type. The orbital shaker maintains cells in suspension while running the plate and allows for consistent and reproducible results.

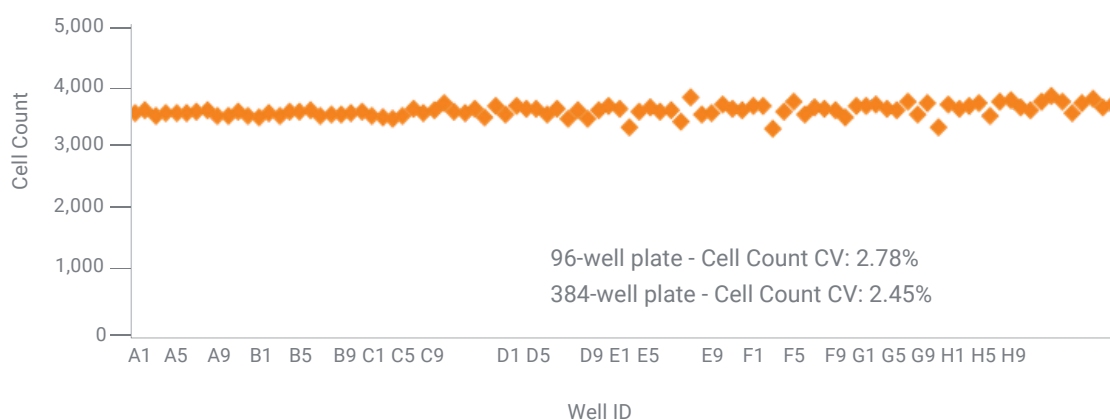

Absolute cell count in individual wells of a 96-well plate

Learn [www.agilent.com/chem/novocyte](http://www.agilent.com/chem/novocyte) more:

Buy online:

[www.agilent.com/chem/store](http://www.agilent.com/chem/store)

U.S. and Canada

1-800-227-9770

[agilent\\_inquiries@agilent.com](mailto:agilent_inquiries@agilent.com)

Europe [info\\_agilent@agilent.com](mailto:info_agilent@agilent.com)

Asia Pacific

[inquiry\\_lsca@agilent.com](mailto:inquiry_lsca@agilent.com)



**Altium International Sp. z o.o.**  
ul. Puławska 303, 02-785 Warszawa  
telefon +48 22 549 14 00  
[bio.pl@altium.net](mailto:bio.pl@altium.net)  
[www.perlan.com.pl](http://www.perlan.com.pl)  
[www.altium.net](http://www.altium.net)

For Research Use Only. Not for use in diagnostic procedures.

DE.6635532407

This information is subject to change without notice.

© Agilent Technologies, Inc. 2021  
Published in the USA, January 08, 2021  
5994-1598EN

